

<i>Document name</i>	<i>Issued date</i>	<i>Issued by</i>
Cooling Water flow calc.doc	16 March, 2000	Jodie Tonner

### Estimating seawater flow requirements for a thermal desalination plant

The seawater flow is required to provide to functions; firstly to cool the process and maintain temperature equilibrium, secondly to provide the seawater make-up flow to the evaporation process. The former requirement of cooling the system is the over riding design criteria in normal thermal desalination applications.

The steps in the calculation are as follows;

1. Calculate the heat flow into the process. The plant capacity and gained output ratio are used in this calculation.

SI Units	US Customary Units
$W_d$ = Plant capacity in tonnes per day of water $R$ = Gained output ratio in kg of water per kg of steam $Q$ = heat input = kW =  $\frac{W_d \times 1000 \times 2326}{24 \times R \times 3600}$	$W_d$ = Plant capacity in us gallons per day of water $R$ = Gained output ratio in lb of water per lb of steam $Q$ = heat input = BTU/hr =  $\frac{W_d \times 8.34 \times 970}{24 \times R}$
where 2326 is the average latent heat in kJ/kg	where 8.34lb is the weight of each gallon of water, 970 is the average latent heat in BTU/lb.

2. For estimating purposes it is assumed that 90% of the heat input to the system is removed via the cooling water flow with the balance being removed in the distillate, brine and condensate streams plus vent and radiation losses.

3. Assuming there is no environmental limits the cooling water flow will be based on rejecting 0.9Q with the maximum temperature rise permitted by the process.

For MSF systems the temperature rise is usually no more than 2.5°C/4.5°F per reject section stage where there are normally three stages giving a total rise of approximately 7 – 8 °C. The maximum temperature rise is the difference between the approach to the first reject stage brine temperature and the seawater temperature.

Multiple effect and thermocompressor processes can accept a higher temperature rise and the cooling water outlet temperature is normally fixed to about a 3°C approach to the condenser temperature which is typically 45°C. So with 25°C feedwater the maximum rise can be 17°C.

SI Units	US Customary Units
$0.9Q = m c \Delta T$ <p>where m is the cooling water flow, c is the specific heat capacity and <math>\Delta T</math> is the maximum temperature rise Rearranging for m in kg/s with Q in kW and c in kJ/kgK;</p> $\frac{0.9Q}{4.10 \times \Delta T}$	$0.9Q = m c \Delta T$ <p>where m is the cooling water flow, c is the specific heat capacity and <math>\Delta T</math> is the maximum temperature rise Rearranging for m in lb/hr with Q in BTU/hr and c in BTU/lb-°F;</p> $\frac{0.9Q}{0.96 \times \Delta T}$

4. If there are environmental limits the cooling water flow will be based on rejecting 0.9Q with the maximum temperature rise permitted by the environmental regulation not the process.

Under such circumstances the cooling water flow of all processes will be identical although there may be differences in pressure requirements. The same equations apply but inset the specified  $\Delta T$ .

SI Units	US Customary Units
$0.9Q = m c \Delta T$ <p>where m is the cooling water flow, c is the specific heat capacity and <math>\Delta T</math> is the maximum temperature rise Rearranging for m in kg/s with Q in kW and c in kJ/kgK;</p> $\frac{0.9Q}{4.10 \times \Delta T}$	$0.9Q = m c \Delta T$ <p>where m is the cooling water flow, c is the specific heat capacity and <math>\Delta T</math> is the maximum temperature rise Rearranging for m in lb/hr with Q in BTU/hr and c in BTU/lb-°F;</p> $\frac{0.9Q}{0.96 \times \Delta T}$

---

The information submitted in this publication is based on our current knowledge and experience. In view of the many factors that may affect processing and application, these data do not relieve processors from the responsibility of carrying out their own tests and experiments; neither do they imply any legally binding assurance of certain properties or of suitability for a specific purpose. It is the responsibility of those to whom we supply our products to ensure that any proprietary rights and existing laws and legislation are observed.



## Multiple Effect Evaporation (with Thermal Vapor Compression)

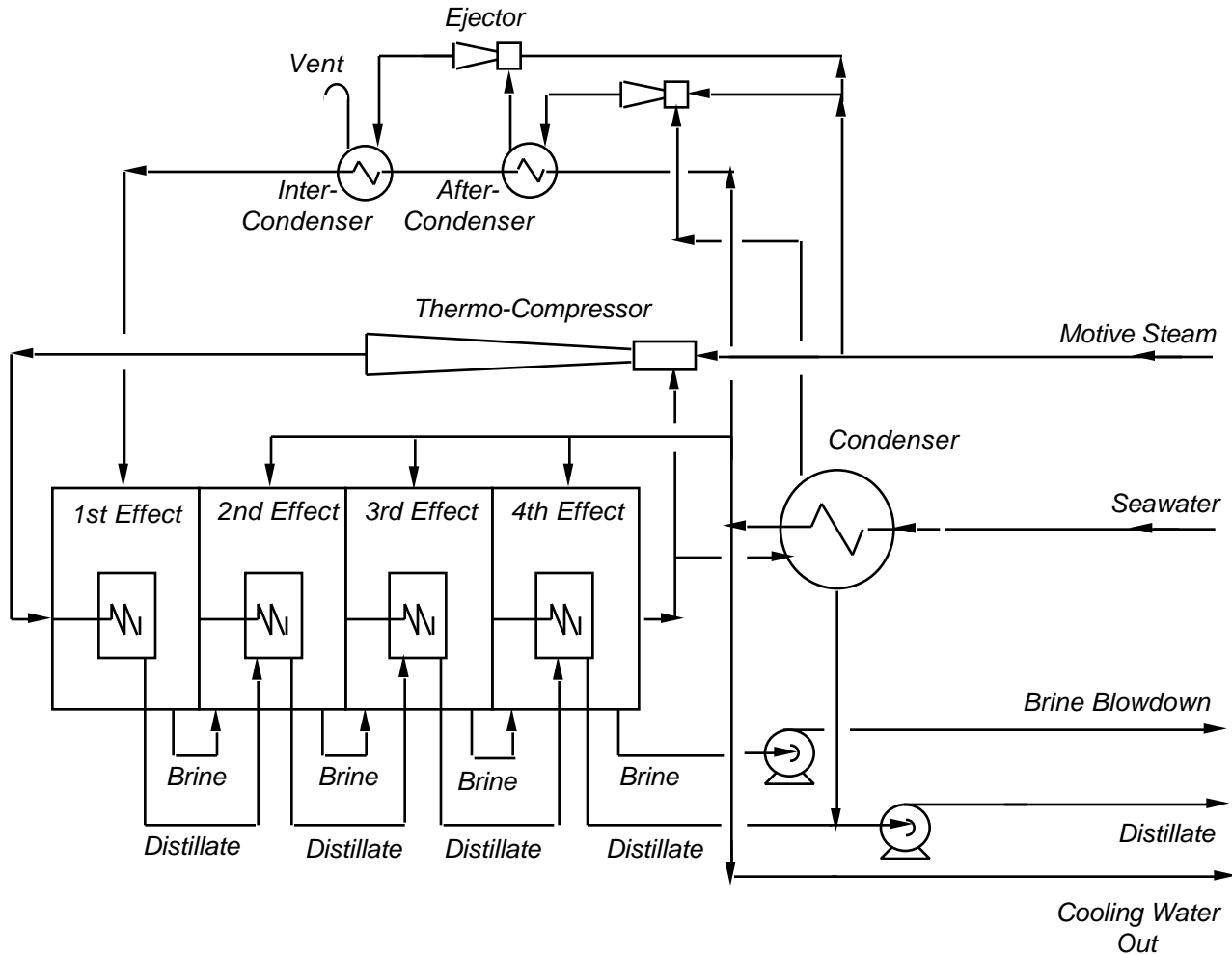

The information submitted in this publication is based on our current knowledge and experience. In view of the many factors that may affect processing and application, these data do not relieve processors from the responsibility of carrying out their own tests and experiments; neither do they imply any legally binding assurance of certain properties or of suitability for a specific purpose. It is the responsibility of those to whom we supply our products to ensure that any proprietary rights and existing laws and legislation are observed.